

INSTALLATION, USE AND MAINTENANCE INSTRUCTIONS FOR THE AC-CE SERIES BLADDER-TYPE PRESSURE TANKS

The ELBI interchangeable bladder-type pressure tanks are available from 5 to 5000 liter capacity

that covers every possible water lifting need in hydraulic systems, from the smallest domestic use to the largest industrial applications.

NOTICES

- This product is suitable to contain water up to +99°C.
- Do not exceed the max. working pressure and temperature of the tank; provide suitable controls to avoid that.
- In order to avoid leaks from the tank, it could be necessary the use of a drainage system.
- During the installation, provide for appropriate discharging and vent valves.
- During the design we have not considered any external stress like traffic, wind, earthquake. These stress elements should be considered by the Installer during the installation.
- Observe local regulations for installation. Qualified professional staff must check the system periodically.
- The manufacturer does not accept any responsibility for material/personal damages due to wrong installation of the vessel.
- If temperature and pressure limits will be exceeded, manufacturer will not accept any responsibility and warranty claims will be refused.
- Check the fluid compatibility for liquids different from water.
- The place of installation should be protected: entry allowed to authorized staff only.
- The device should be protected by suitable heart dump systems, or insulated from the plant by means of a dielectric joint.

Proceed as follows for pressure tank installation:

1. If a tank in an existing system is being replaced, make sure that electrical input to the pump electrical control panel is disconnected and that either the water supply is cut off or the system is completely drained.
2. If the existing system uses a traditional tank (without bladder), eliminate the air supply devices and the level indicator, etc.
3. Take the tank out of its package, remove the protection plug (Fig. 3, No. 9) from the air valve and then check the preloading pressure, making sure that this pressure is slightly less than the pressure-switch triggering pressure and adding or removing air as required, and then screw the protection plug back on. Position the tank as close as possible to the pressure-switch in order to avoid pressure losses due to friction. Figures 1 and 2 illustrate the most frequent types of installation.
4. Connect the tank to the water mains or to the pump outlet point, making sure to always respect all local installation regulations.
5. We recommend installing a safety valve set to the system maximum working pressure. The safety valve and the pressure gauge must be positioned near the indication "A" in Fig. 1 and 2; otherwise, the bladder support stay-bolt must be closed off with a 3/4" plug.
6. Restore the power supply to the pump control panel only after completing the installation of the tank.
7. Fill the system again by starting up the pump until the pressure-switch shuts the pump off automatically.
8. Open and close the cock furthest from the tank repeatedly in order to eliminate all the air inside the tubing.
9. Open one or more cocks in order to empty the tank. If a pause is observed between the emptying of the tank and the starting of the pump, the pressure-switch triggering pressure must be slightly increased (consult the instructions provided by the Manufacturer) or the tank pre-loading pressure must be decreased by proceeding as described in Point 3.
10. Repeat Points 8, 9 and 10 until the pause is completely eliminated.
11. Check all the connections and make sure that there are no leakages of water.
12. If the operations in all the Points above have been perfectly executed, the system should now be ready for operation.
13. Regularly check the tank pre-loading pressure during the use of the system and top up whenever required.

Proceed as follows for the replacement of the bladder (See Fig. 4):

1. Disconnect the power supply to the pump electrical control panel and either shut off the water supply or completely drain the system of water.
2. Remove the tank from the system and remove all the pre-loading air by using Valve (5).
3. Position the tank horizontally in order to facilitate the operations that follow.
4. Remove the bolts (1) from the counter-flange (2) and then remove the counter-flange.
5. Remove the old bladder from the tank.
6. Re-assemble the counter-flange, screw the bolts back in place.
7. Re-load the tank pre-loading pressure and check for leakages of air on the counter-flange.
8. Re-connect the tank to the system and follow the instructions prescribed from Point 7 onwards for the verification of correct system operation.

MAINTENANCE

Before starting any maintenance, disconnect all the electric devices and take care of the pressure and temperature of the system. All the heating system components should be periodically checked by professional people (at least once per year)

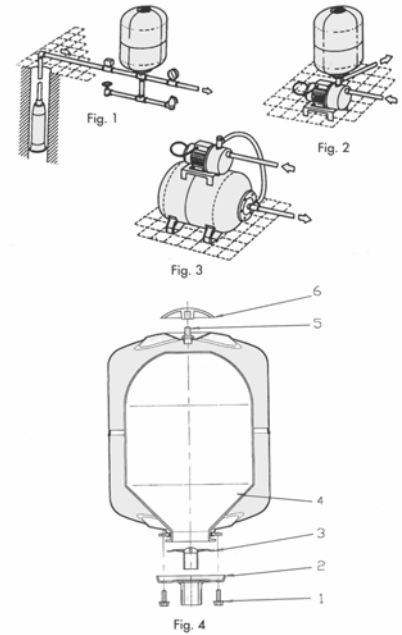

CAPTION

1. Counterflange bolts
2. Counterflange
3. Counterflange protection
4. Bladder
5. Pre-loading valve
6. Protection cup