

C2 Lite CAD™ SERIES



FEATURES

- Patented CAD-2 diaphragm technology
- Unique 3 piece construction
- Reinforced Plastic Connection
- Durable continuous strand fiberglass sealed with epoxy resin
- NSF Standard 61, CE/PED, WRAS, ACS, ISO:9001 approved
- Rugged copolymer polypropylene base
- Quality brass air stem with o-ring seal
- No sweat design
- Comprehensive testing
- No maintenance

If you are looking for the proven performance of a GWS steel tank in a lightweight composite design, C2-Lite CAD™ series is the answer. Efficient and cost effective, C2-Lite CAD™ tanks are designed with the patented controlled action diaphragm design of GWS Challenger™ tanks. Unlike other composite tanks that hide tired old bag technology in a plastic shell, the patented CAD-2 diaphragm design is stronger and will not crease and wear out. It features a chlorine resistant 100% butyl diaphragm with a precision molded copolymer polypropylene liner for superior air and water separation. This patented design allows each size tank to have a properly sized water chamber matched to the drawdown performance of that tank. C2-Lite CAD™ tanks are easy to install, weather resistant and engineered to withstand even extreme environmental conditions. When it comes to performance and durability, the GWS C2-Lite CAD™ design cannot be beat.

C2-Lite CAD™ tanks are quality tested at several stages on the production line to insure the structural integrity of every tank. C2-Lite CAD™ tanks represent the best value for the investment and are the best quality composite vessels available today.

SPECIFICATIONS C2-Lite CAD™ Series Models

BSP	NTP	Nominal Volume		Shipping (box) Volume		Shipping (box) Weight		Dimensions							
		liter	gal	m ³	ft ³	kg	lbs	A		B		C		D	
								cm	inches	cm	inches	cm	inches	cm	inches
C2B-60LV	C2N-15GV	60	15	0.13	4.44	8.62	19.0	65.01	25.59	4.50	1.75	42.13	16.60	23.88	9.40
C2B-80LV	C2N-20GV	80	20	0.16	5.79	10.89	24.0	86.50	34.06	4.50	1.75	42.13	16.60	23.88	9.40
C2B-100LV	C2N-25GV	100	25	0.19	6.66	12.70	28.0	98.03	38.59	4.50	1.75	42.13	16.60	23.88	9.40
C2B-130LV	C2N-35GV	130	35	0.23	8.26	15.42	34.0	124.15	48.88	4.50	1.75	42.13	16.60	23.88	9.40
C2B-200LV	C2N-50GV	200	50	0.35	12.24	20.19	44.5	109.91	43.27	5.70	2.25	54.60	21.50	30.23	11.90
C2B-250LV	C2N-65GV	250	65	0.41	14.50	24.95	55.0	135.47	53.33	5.70	2.25	54.60	21.50	30.23	11.90
C2B-300LV	C2N-80GV	300	80	0.52	18.23	28.12	62.0	164.43	64.74	5.70	2.25	54.60	21.50	30.23	11.90
C2B-350LV	C2N-90GV	350	90	0.59	20.66	33.11	73.0	144.84	57.02	5.70	2.25	61.77	24.30	34.04	13.40
C2B-450LV	C2N-120GV	450	120	0.74	26.06	36.29	80.0	183.16	72.11	5.70	2.25	61.77	24.30	34.04	13.40

Max. Working Pressure 8.6 bar / 125 psi
 Max. Working Temperature 49°C / 120°F
 Connection C2B-60LV - C2B-130LV 1" BSP
 C2B-200LV-C2B-450LV 1 1/4" BSP
 C2N-15GV - C2N-35GV 1" NPT C2N-50GV - C2N-120GV 1 1/4" NPT
 Please refer to tank packaging for correct factory set pre-charge information.

Note: Minor dimensional variation may occur

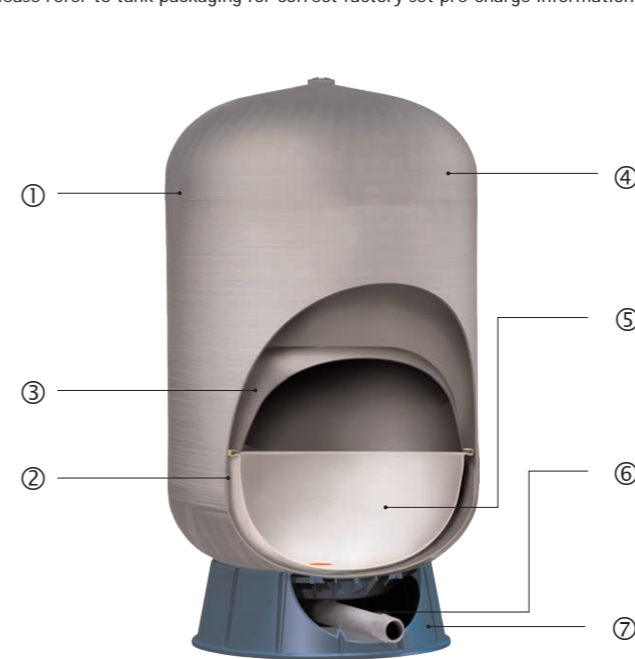

- ① Precision injection molded domes
- ② High-tech spin welding process
- ③ Patented CAD-2 controlled action diaphragm design
- ④ Durable continuous strand fiberglass sealed with epoxy resin
- ⑤ Virgin Polypropylene Liner
- ⑥ Reinforced Plastic Connection
- ⑦ Rugged base

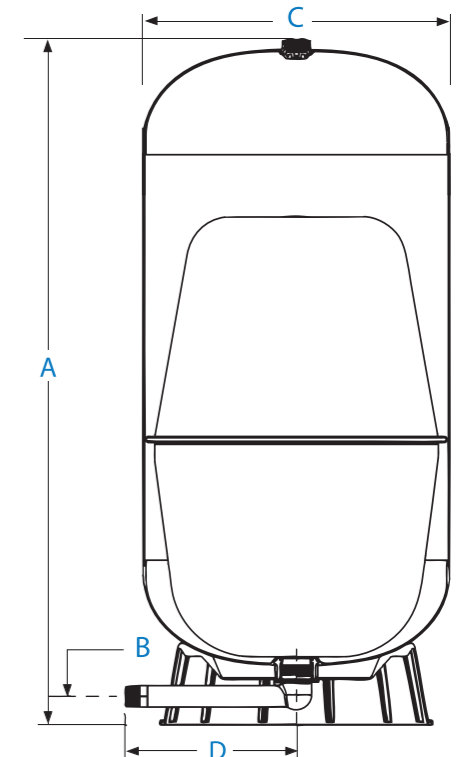

ISO:9001



ACS Approved

