

esybox MAX

ELECTRONIC BOOSTER SET



ESYBOX MAX

ELECTRONIC BOOSTER SET



TECHNICAL DATA

Flow rate: Up to 17,4 m³/h (For single unit)

Head: 113 m

Type of pumped liquid: Clean, free from solid or abrasive substances, non-viscous, non-aggressive, non-crystallized and chemically neutral

Liquid temperature: +50°C

Maximum ambient temperature: +55°C

Maximum inlet pressure: 5 bar

Operation pressure: 12 bar / 1200 kPa

Constant pressure range: 1-12 bar (3 bar by default)

Motor protection class: IP X5

Motor insulation class: F

Impeller material: Technopolymer

Single phase power input: 208-240V 50/60Hz

Three phase power input: 380-480V 50/60Hz

Type of installation: Fixed in vertical position

Certification: WRAS, ACS, NSF61 (are pending approval)

Integrated pumping system for pressurization in commercial building service. Available in two power sizes, it consists of modular elements that allow different configurations to cover the needs of medium/large condominiums and high buildings (even over 14 floors).

Each unit consists of the single, double or triple connection base and the pumping units; a four-pumps system is available with the additional kit to connect two double bases.

The modular construction allows to assemble the pumping groups directly at the installation site (O.S.A. concept).

The silence and compactness of dimensions allow installation in all rooms, even inhabited.

CONSTRUCTION FEATURES OF THE PUMP

Electronic vertical multi-impeller pump, with display, pressure sensors on intake and delivery, non-return valve on delivery and an integrated expansion tank. Pump body and impellers in technopolymer with steel jacket.

CONSTRUCTION FEATURES OF THE MOTOR

Water-cooled permanent magnet motor, stainless steel motor jacket. Motor shaft in AISI 303 stainless steel.

CONSTRUCTION FEATURES OF THE ELECTRONIC

The variable frequency drive keeps the pressure constant by varying the number of motor revolutions according to the request.

The expansion module (esy I/O, available as an accessory) makes it possible to interface Esybox Max with the other elements of the system (BMS).

Integrated protections: protection from dry running, amperometric and abnormal voltages, overheating, freezing, anti-blocking and anti-cycling.

DCONNECT

It is possible to configure and view the operating parameters on the large Esybox Max display or thanks to the DConnect app and the integrated Wi-Fi module, it is possible to do it remotely with an active DConnect service (an Internet connection is required).

From a smartphone or a tablet it is possible to control and manage system pressure, alarms and check the instantaneous and historical consumption.

With DSync technology, the user experience of Esybox Max is simplified. Using their smartphone or tablet, the installer interfaces with the pump that automatically detects the language, the time and the unit of measurement used in the Country of installation. In the case of a booster set, once the installation of the first pump is completed, the Esybox Max automatically synchronize the other pumps. The DSync also allows you to connect the pump to the outside world, through the Modbus protocol.

ESYBOX MAX

ELECTRONIC BOOSTER SET

MATERIAL

N°	PARTS	MATERIALS
1	FITTING	TECHNOPOLYMER PA66 30%GF
2	MANIFOLD	AISI 304 STEEL
3	FLANGE	TECHNOPOLYMER PA66 30%GF
4	PUMP BODY	TECHNOPOLYMER PA66 30%GF
5	PUMP BODY RING	TECHNOPOLYMER PP 30%GF
6	IMPELLER	TECHNOPOLYMER PPO 30%GF / AISI 304 STEEL
7	DIFFUSER	TECHNOPOLYMER PPO 30%GF / AISI 304 STEEL
8	MOTOR AXIS	AISI 303 STEEL
9	O-RING	EPDM
10	O-RING	EPDM
11	MOTOR FLANGE	TECHNOPOLYMER PA66 30%GF
12	MECHANICAL SEAL	CARBON IMPREGNATED RESIN / SILICON CARBIDE / EPDM
13	O-RING	EPDM
14	MOTOR LINER	AISI 304 STEEL
15	MOTOR BODY	TECHOPOLYMER PA66 30%GF
16	O-RING	EPDM
17	CONVEYOR TUBE	TECHNOPOLYMER PP 30%GF
18	PRESSURE SENSOR	TECHOPOLYMER NYLON / EPDM
19	NON RETURN VALVE	TECHOPOLYMER POM / EPDM / AISI 302 STEEL
20	NON RETURN VALVE BODY	TECHNOPOLYMER PA66 30%GF
21	TANK	TECHOPOLYMER NORYL / RUBBER
22	DELIVERY BODY	TECHNOPOLYMER PA66 30%GF
23	OUTER LINER	AISI 304 STEEL

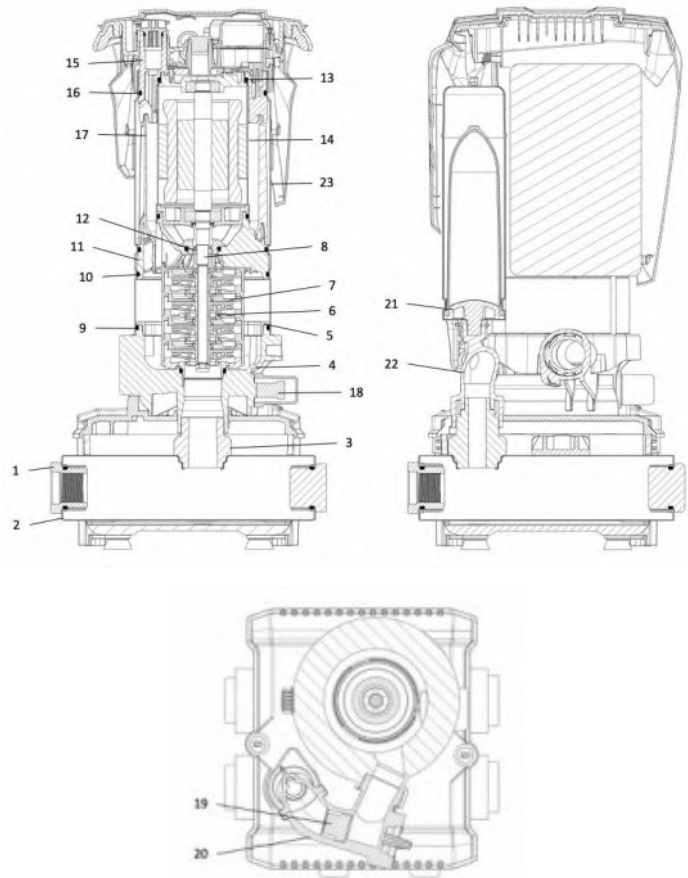

PERFORMANCE RANGE

The performance curves are based on kinematic viscosity values = 1 mm²/s and density equivalent to 1000 kg/m³. Curve tolerance according to ISO 9906.

GRAPHIC SELECTION TABLE

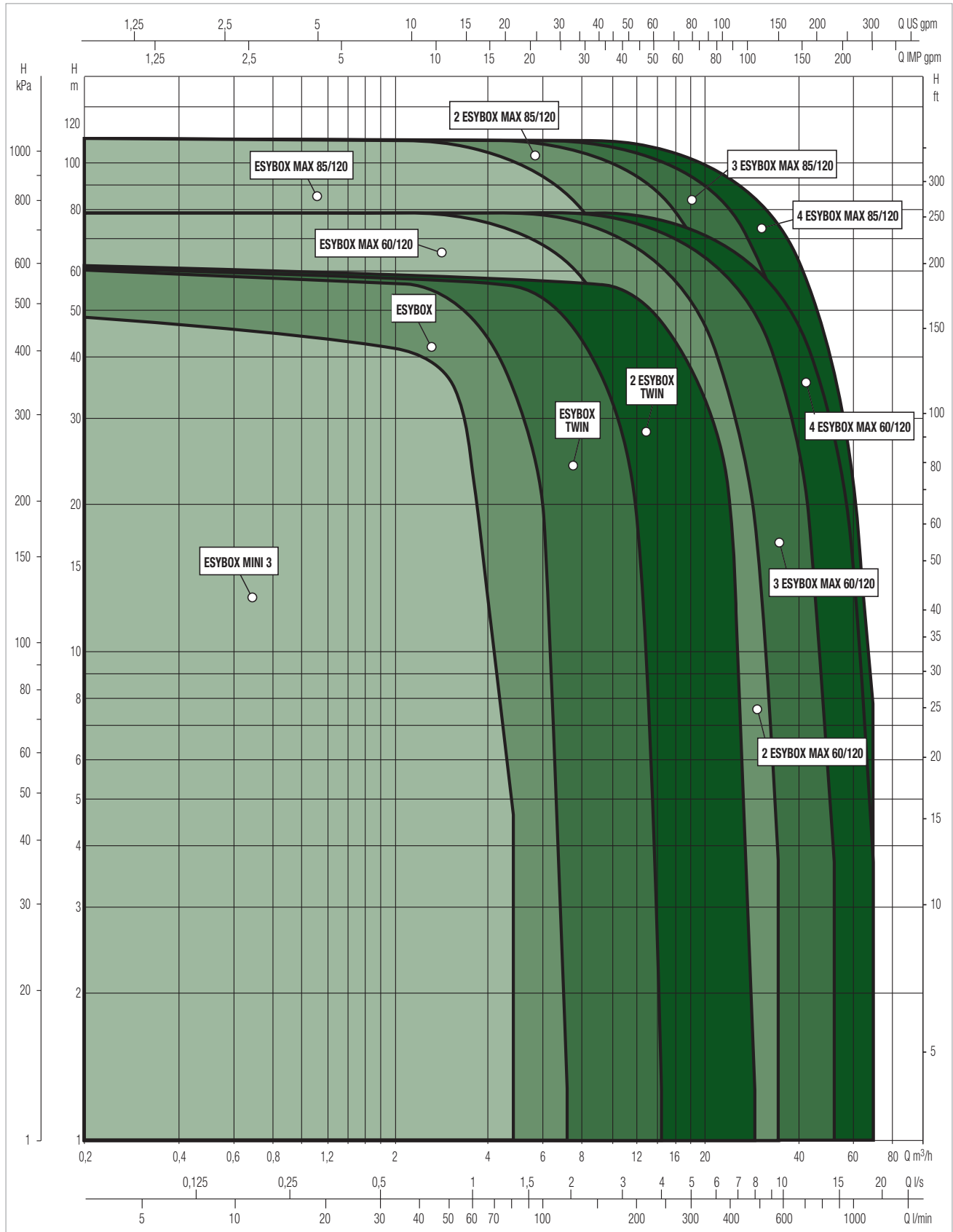

SELECTION TABLE

MODEL	Q=m ³ /h	0,0	2,4	3,6	4,8	6,0	7,2	8,4	9,6	10,8	12,6	14,4	17,4
	Q=l/min	0	40	60	80	100	120	140	160	180	210	240	290
ESYBOX MAX 60/120 M	H (mt)	80	79,5	77,1	73,4	68,5	62	55,5	48,2	41	30,5	21	4
ESYBOX MAX 60/120 T		80	79,5	77,1	73,4	68,5	62	55,5	48,2	41	30,5	21	4
ESYBOX MAX 85/120 T		113	110	106,5	101	93	84	75	65,5	56,7	43,5	31	8,5

MODEL	Q=m ³ /h	0	4,8	7,2	9,6	12	14,4	16,8	19,2	21,6	25,2	28,8	34,8
	Q=l/min	0	80	120	160	200	240	280	320	360	420	480	580
2 ESYBOX MAX 60/120 M	H (mt)	80	79,5	77,1	73,4	68,5	62	55,5	48,2	41	30,5	21	4
2 ESYBOX MAX 60/120 T		80	79,5	77,1	73,4	68,5	62	55,5	48,2	41	30,5	21	4
2 ESYBOX MAX 85/120 T		113	110	106,5	101	93	84	75	65,5	56,7	43,5	31	8,5

MODEL	Q=m ³ /h	0	7,2	10,8	14,4	18	21,6	25,2	28,8	32,4	37,8	43,2	52,2
	Q=l/min	0	120	180	240	300	360	420	480	540	630	720	870
3 ESYBOX MAX 60/120 M	H (mt)	80	79,5	77,1	73,4	68,5	62	55,5	48,2	41	30,5	21	4
3 ESYBOX MAX 60/120 T		80	79,5	77,1	73,4	68,5	62	55,5	48,2	41	30,5	21	4
3 ESYBOX MAX 85/120 T		113	110	106,5	101	93	84	75	65,5	56,7	43,5	31	8,5

MODEL	Q=m ³ /h	0	9,6	14,4	19,2	24	28,8	33,6	38,4	43,2	50,4	57,6	69,6
	Q=l/min	0	160	240	320	400	480	560	640	720	840	960	1160
4 ESYBOX MAX 60/120 M	H (mt)	80	79,5	77,1	73,4	68,5	62	55,5	48,2	41	30,5	21	4
4 ESYBOX MAX 60/120 T		80	79,5	77,1	73,4	68,5	62	55,5	48,2	41	30,5	21	4
4 ESYBOX MAX 85/120 T		113	110	106,5	101	93	84	75	65,5	56,7	43,5	31	8,5

ESYBOX MAX - ELECTRONIC BOOSTER SET

Liquid temperature: +50°C - Maximum ambient temperature: +55°C

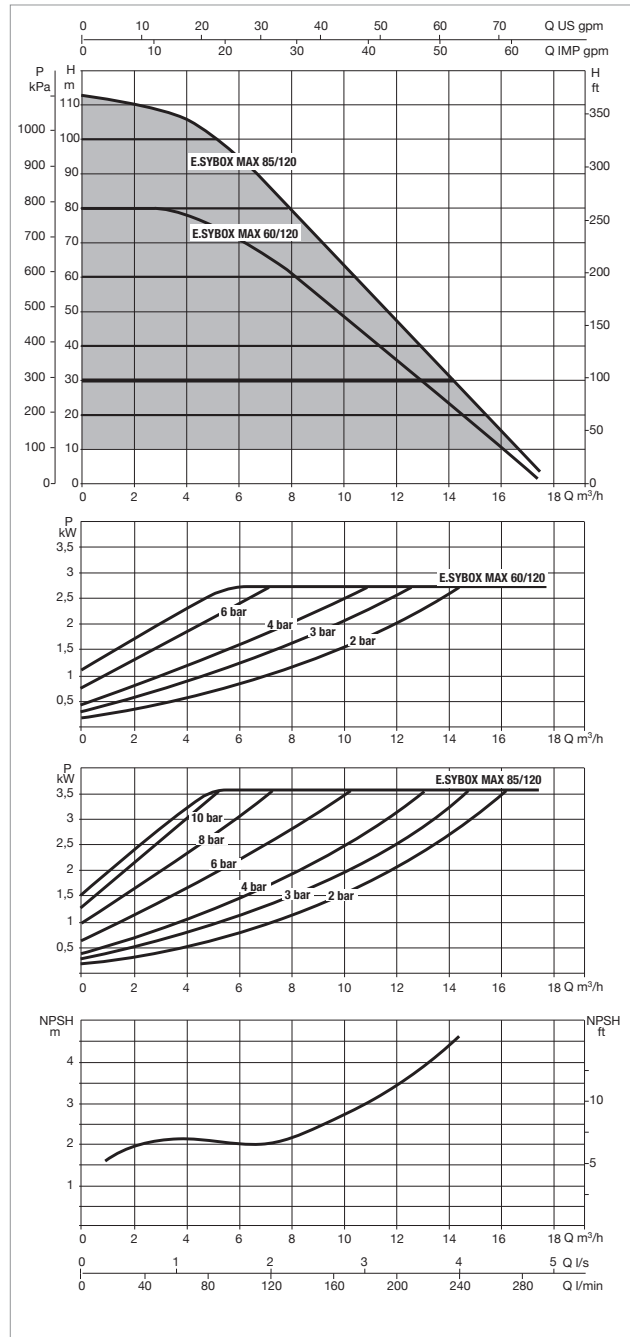
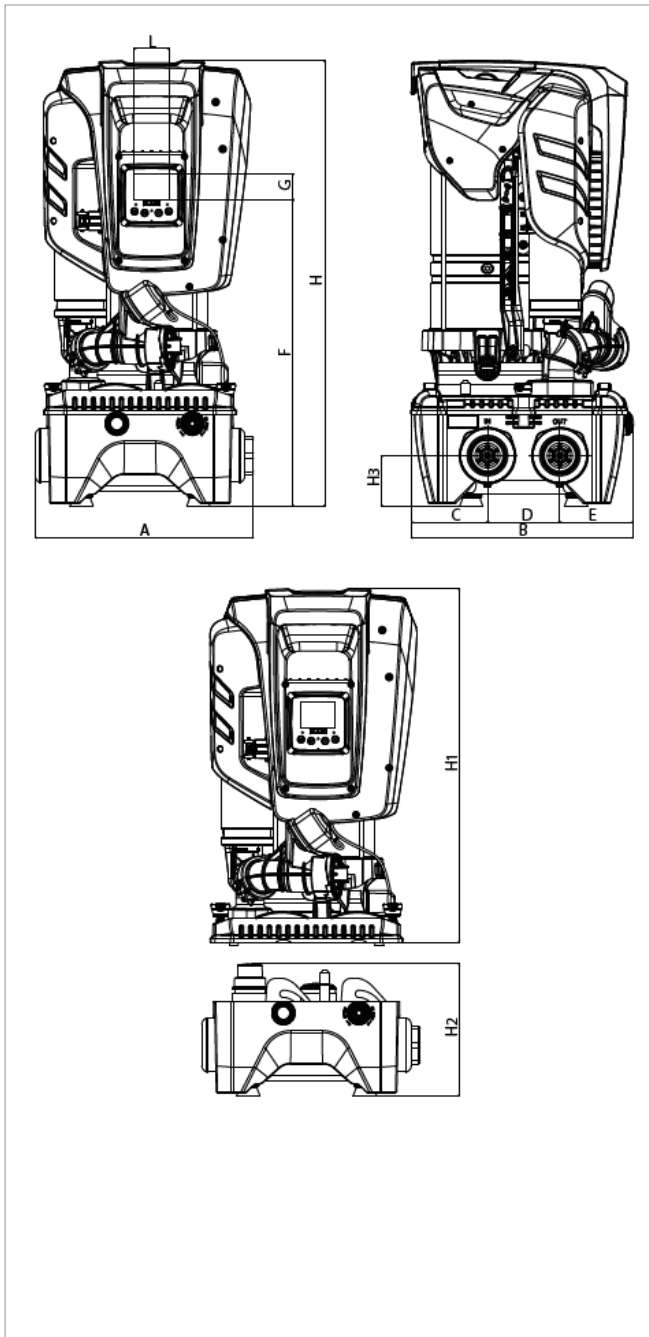

The performance curves are based on the kinematic viscosity values = 1 mm²/s and density equivalent to 1000 kg/m³. Curve tolerance according to ISO 9906.

MODEL	N° IMPELLERS	POWER SUPPLY 50/60 Hz	ELECTRICAL DATA			
			P1 MAX		In A	SET POINT
			kW	HP		
ESYBOX MAX 60/120 M	3	1x208-240V ~	2,68	3,6	12,5 - 11,5	1-12
ESYBOX MAX 60/120 T	3	3x380-480V ~	2,65	3,5	4,4	1-12
ESYBOX MAX 85/120 T	4	3x380-480 V ~	3,50	4,7	5,6	1-12

MODEL	A	B	C	D	E	F	G	H	H1	H2	H3	L	DNA	DNM	PACKING DIMENSIONS*			WEIGHT* PUMP UNIT Kg	PACKING DIMENSIONS DOCK			WEIGHT DOCK Kg
															PUMP UNIT				DOCK			
															L/A	L/B	H	L/A	L/B	H		
ESYBOX MAX 60/120	375	384	131.8	124.5	127.7	526	45	766	613	228	87	59,5	1"1/4 - 2"	1"1/4 - 2"	400	380	800	29	400	400	250	9
ESYBOX MAX 85/120	375	384	131.8	124.5	127.7	526	45	766	613	228	87	59,5	1"1/4 - 2"	1"1/4 - 2"	400	380	800	30	400	400	250	9

* Weights and packaging dimensions refer to a pump unit



2 ESYBOX MAX - ELECTRONIC BOOSTER SET

Liquid temperature: +50°C - Maximum ambient temperature: +55°C

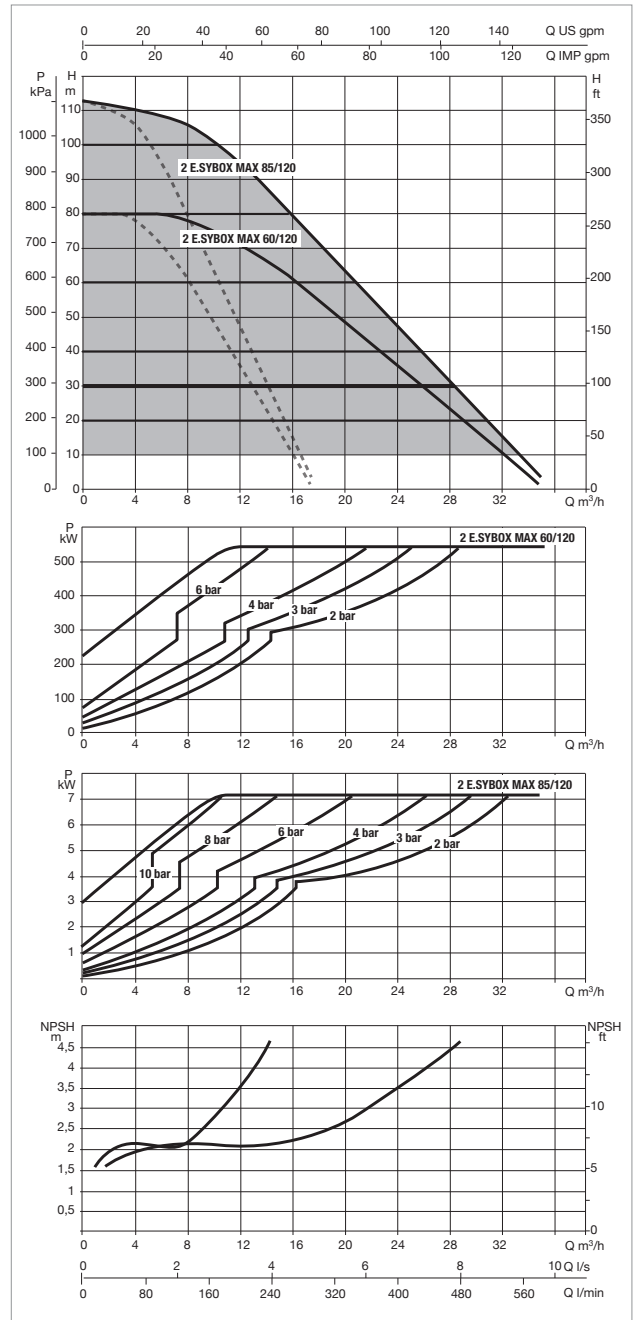
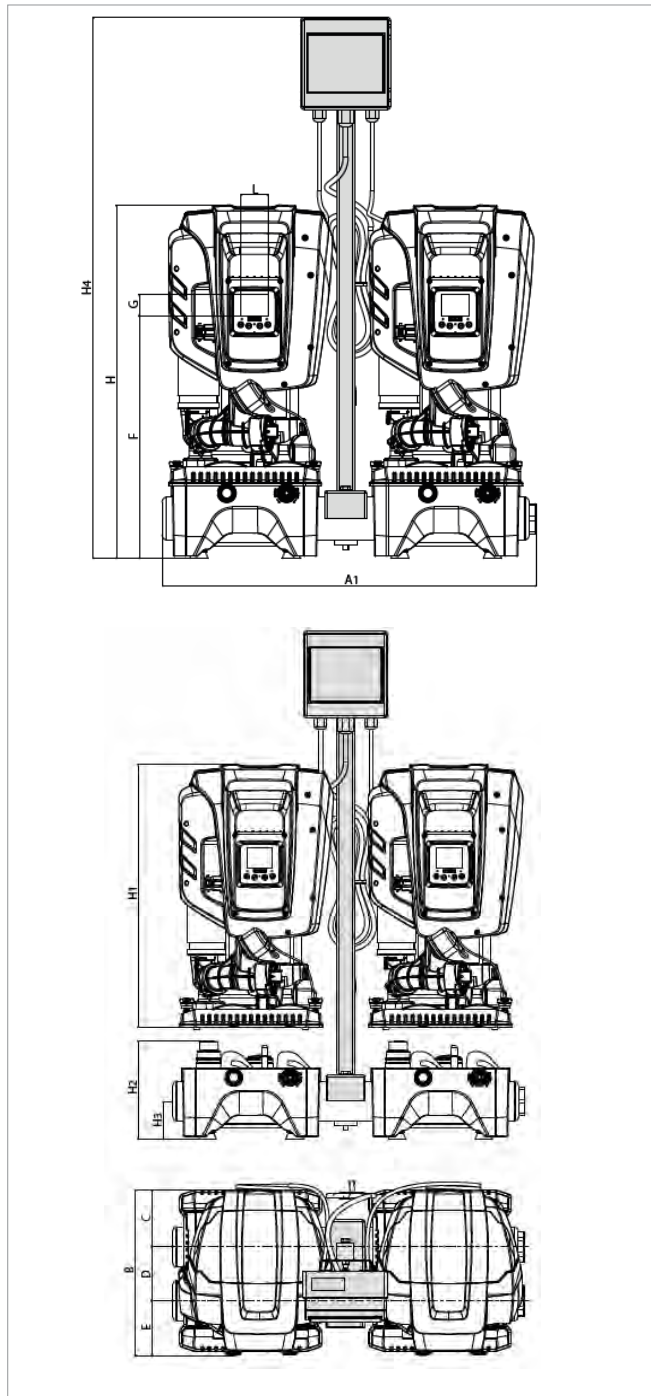

The performance curves are based on the kinematic viscosity values = 1 mm²/s and density equivalent to 1000 kg/m³. Curve tolerance according to ISO 9906.

For the four pumps version, the flow rate is the double.

MODEL	ELECTRICAL DATA					
	N° IMPELLERS	POWER SUPPLY 50/60 Hz	P1 MAX		2x In A	SET POINT
			2x kW	2x HP		
2 ESYBOX MAX 60/120 M	3	1x208-240 V ~	2,68	3,6	12,5 - 11,5	1-12
2 ESYBOX MAX 60/120 T	3	3x380-480 V ~	2,65	3,5	4,4	1-12
2 ESYBOX MAX 85/120 T	4	3x380-480 V ~	3,50	4,7	5,6	1-12

MODEL	A1	B	C	D	E	F	G	H	H1	H2	H3	H4**	L	DNA	DNM	PACKING DIMENSIONS*			WEIGHT* PUMP UNIT Kg	PACKING DIMENSIONS DOCK			WEIGHT DOCK Kg
																PUMP UNIT				DOCK			
																L/A	L/B	H		L/A	L/B	H	
2 ESYBOX MAX 60/120	811	384	131.8	124.5	127.7	526	45	766	613	228	87	1172	59.5	2"	2"	400	380	800	29	900	400	250	18
2 ESYBOX MAX 85/120	811	384	131.8	124.5	127.7	526	45	766	613	228	87	1172	59.5	2"	2"	400	380	800	30	900	400	250	18

* Weights and packaging dimensions refer to a pump unit **Control panel and Mounting bracket sold separately as optional accessories



3 ESYBOX MAX - ELECTRONIC BOOSTER SET

Liquid temperature: +50°C - Maximum ambient temperature: +55°C

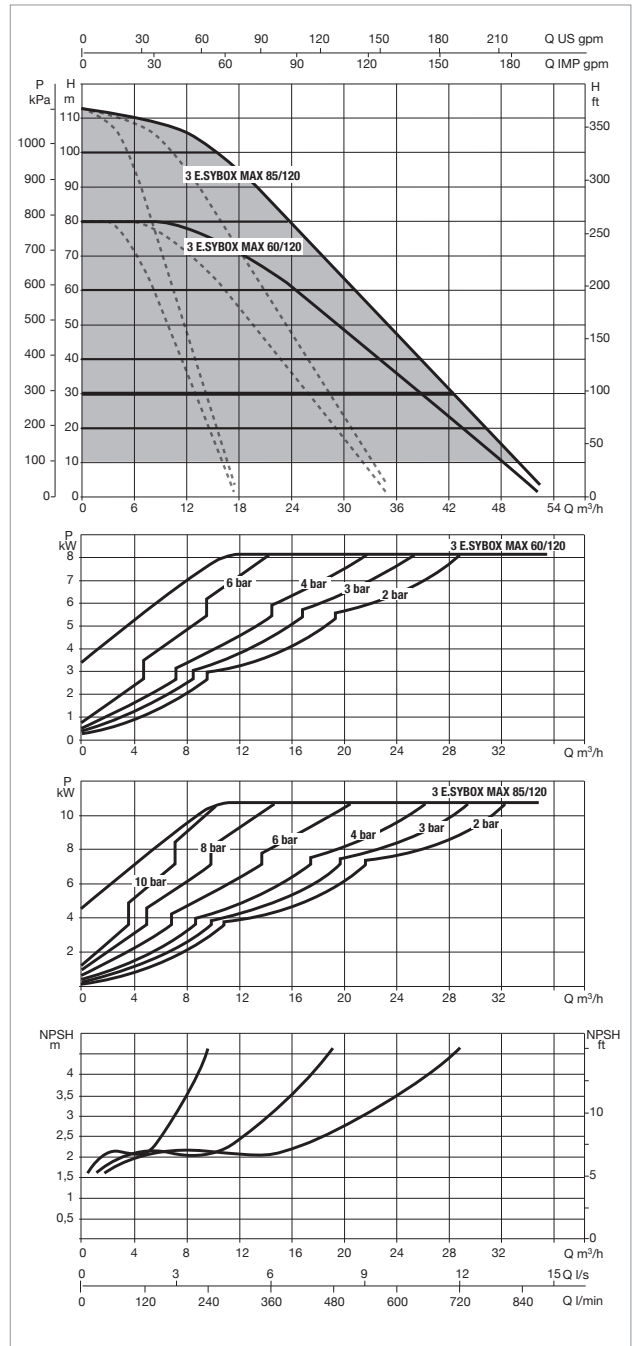
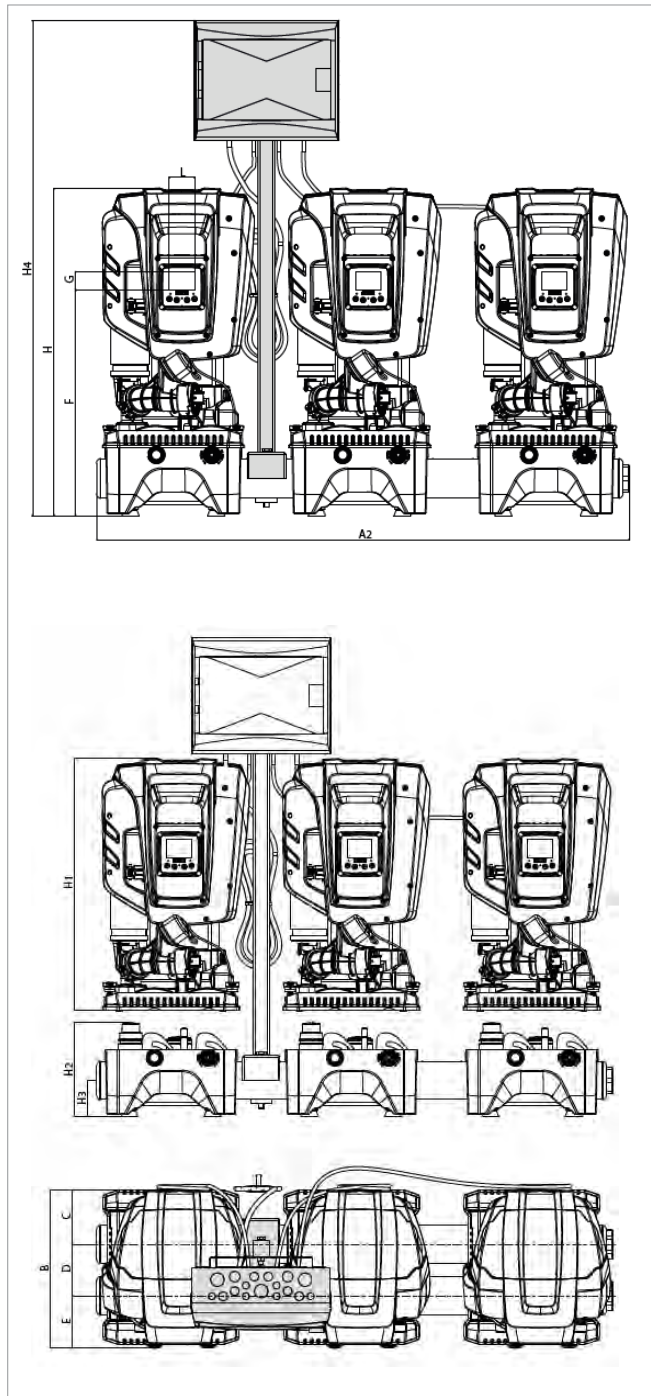

The performance curves are based on the kinematic viscosity values = 1 mm²/s and density equivalent to 1000 kg/m³. Curve tolerance according to ISO 9906.





MODEL	ELECTRICAL DATA					
	N° IMPELLERS	POWER SUPPLY 50/60 Hz	P1 MAX		3x In A	SET POINT
			3x kW	3x HP		
3 ESYBOX MAX 60/120 M	3	1x208-240V ~	2,68	3,6	12,5 - 11,5	1-12
3 ESYBOX MAX 60/120 T	3	3x380-480V ~	2,65	3,5	4,4	1-12
3 ESYBOX MAX 85/120 T	4	3x380-480 V ~	3,50	4,7	5,6	1-12

MODEL	A2	B	C	D	E	F	G	H	H1	H2	H3	H4**	L	DNA	DNM	PACKING DIMENSIONS*			WEIGHT* PUMP UNIT Kg	PACKING DIMENSIONS DOCK			WEIGHT DOCK Kg
																L/A	L/B	H		L/A	L/B	H	
																3 ESYBOX MAX 60/120	1250	384	131,8	124,5	127,7	526	45
3 ESYBOX MAX 85/120	1250	384	131,8	124,5	127,7	526	45	766	613	228	87	1158	59,5	2"	2"	400	380	800	30	1250	400	250	27

* Weights and packaging dimensions refer to a pump unit **Control panel and Mounting bracket sold separately as optional accessories

ACCESSORIES

ESYBOX MAX

	DESCRIPTION	MODEL	ESYBOX MAX	2 ESYBOX MAX	3 ESYBOX MAX	4 ESYBOX MAX
	CONTROL PANEL Electrical connection panels for 2 or 3 pumps complete with magnetothermic switches for powering multi-pump units. It can be installed on the wall or directly to Esybox Max units using the dedicated pillar kit.	CONTROL PANEL E2G5,2 M 230V		● Single phase		● 2 x Single phase
		CONTROL PANEL E2G7 T 400V		● Tree- phase		● 2 x Single phase
		CONTROL PANEL E3G10.5 T 400V			● Tree- phase	
	PILLAR KIT Useful for mounting the control panel EG on board of the 2 or 3 Esydock max. The bracket consist in a column, a bolt and a lower clamping bracket (all in steel).					● 2 x
	ESy I/O The electronic expansion module allows Esybox Max to interface with the external input/output devices (eg: float switch, pressure switch, remote alarm) and with the BMS world (Building Management System).		●	●	●	●
	JOINT KIT kit consisting of 2 pieces of 3-piece unions and 2 pieces of 2" nipples to connect the delivery and suction of a pair of 2 esydock max to create 4-unit Esybox max groups.					●