

E.SyTANK

DRINKING WATER STORAGE TANK





*E.SYBOX not supplied with E.SYTANK

TECHNICAL DATA

Operating range: maximum flow rate 120 l/min, head up to 65 metres
Pumped fluid: clean, free from solids or abrasive substances, not viscous, not aggressive, not crystallised and chemically neutral.

Maximum liquid temperature: 40°C

Maximum environment temperature: 50°C

Maximum capacity: 480 litres

Maximum system pressure (c/e.sybox): 8 bar

Supply pressure allowed at mains water inlet: max. 6 bar

Dimensions of mains water inlet pipe: 3/4"

Dimensions of delivery pipe: 1"

Dimensions of overflow pipe connection: DN 50

Dimensions of front discharge (not drilled): DN40

Dimensions of discharge lower discharge (not drilled): DN20

APPLICATION / EXAMPLES OF INSTALLATION

E.SYTANK is the tank for drinking water integrated with the E.SYBOX system for storage, disconnection from the mains and water supply in domestic/residential settings.

E.SYTANK satisfies the following needs:

- Catering for the water requirement, if the public distribution mains is insufficient;
- Disconnection from the mains where it is not allowed to install pumping systems that draw directly from the distribution mains. This occurs mainly to avoid the reflux of water into the distribution mains and its contamination.
- Use as intermediate tanks in tall buildings to divide a pressure boosting system into several areas.

E.SYTANK is the solution that completes E.SYBOX, creating a complete pressure boosting system in a high-efficiency domestic and residential setting, allowing:

- Notable reduction of bulk
- Dimensions suitable for passing through cellar doors
- Tank complete with all the accessories for rapid installation
- Maximum integration and ease of installation of E.SYBOX
- Recyclable Materials
- Tank suitable for potable water

CONSTRUCTION CHARACTERISTICS

E.SYTANK with a net capacity of 480 litres, suitable for use with drinking water.

It has a valve for filling from the water mains with a float with free discharge in compliance with UNI EN 1717 and an overflow system type AG as per the same standard (UNI EN 1717 "Protection against pollution of potable water").

The tank is complete with e.sydock, a suction pipe with foot valve, and a delivery pipe.

The tank is suitable for fixed installation above ground and the four slots on the base allow easy fixing to the ground.

On the front wall there is the possibility of connecting a plug or a discharge pipe with a pipe that can be welded on or glued on.

On the rear, at the bottom, there is access to possible direct drainage under the tank. Both auxiliary discharge points are to be drilled.

System maintenance is also simple thanks to the handy inspection cap. The system is modular thanks to the possibility of installing additional tanks on three sides (at the side and rear).

Nothing else is needed besides e.sytank, in combination with e.sybox, to guarantee correct installation in a residential setting.

MATERIALS

N°	ITEMS	MATERIALS
1	480 LITRE TANK	LINEAR HIGH-DENSITY POLYETHYLENE. HDPE
2	INSPECTION COVER	LINEAR LOW-DENSITY POLYETHYLENE. LDPE
3	SERVO-CONTROLLED FLOAT VALVE	(NYLON) PA 66 GLASS FIBER REINFORCED, STAINLESS STEEL, EPDM, PPH, BRASS CW508L
4	OVERFLOW	PP POLYPROPYLENE 30% GLASS FIBER
5	SUCTION PIPE WITH FOOT VALVE	POLYPROPYLENE HOMOPOLYMER, POM
6	DELIVERY PIPE	POLYPROPYLENE HOMOPOLYMER
7	AUXILIARY DELIVERY PIPE*	POLYPROPYLENE HOMOPOLYMER
8	E.SYDOCK	NYLON 30% FV, PP 30% FV, NBR

*not supplied with E.SYTANK

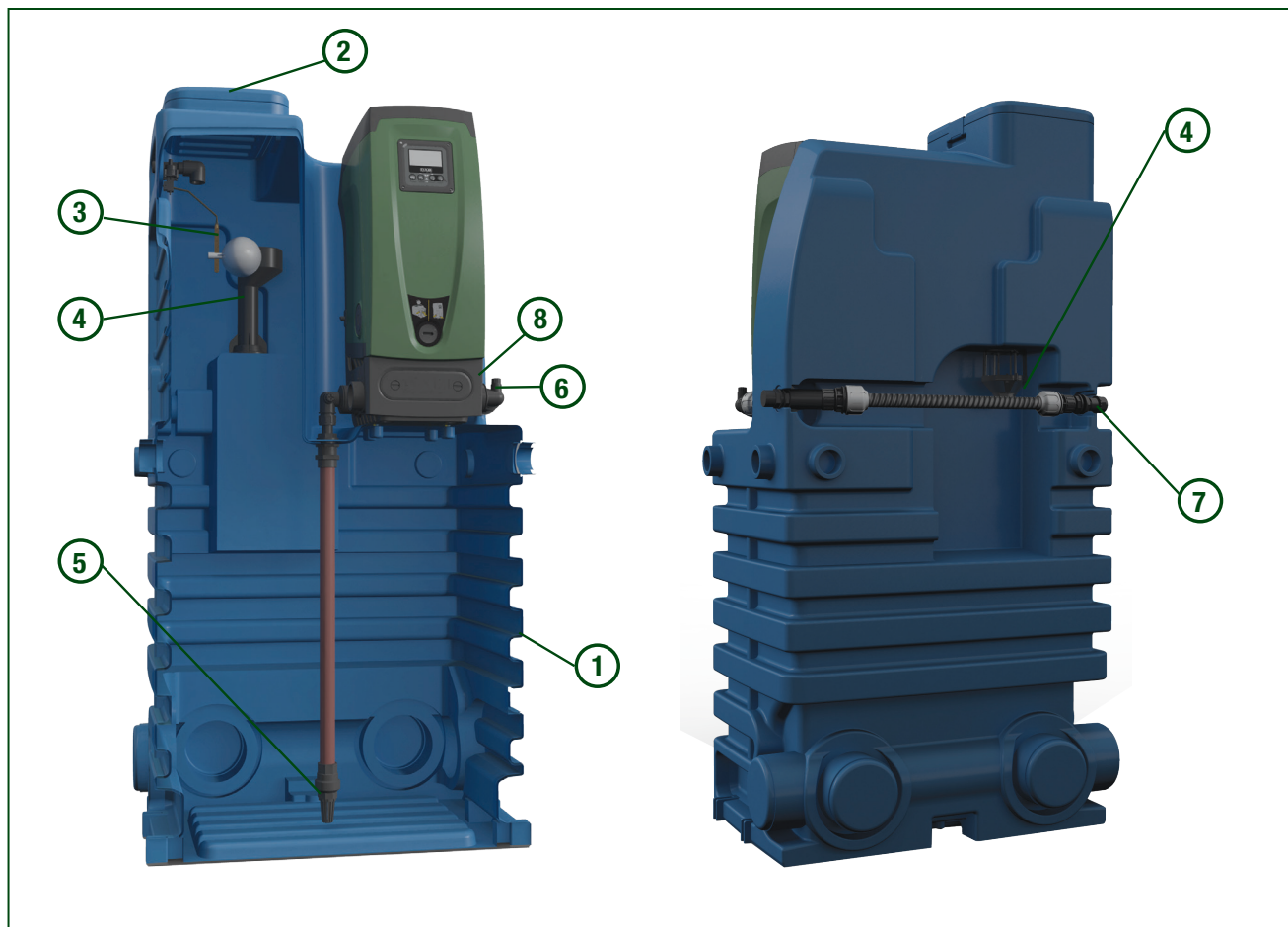

ACCESSORIES

E.SYTANK AUXILIARY CITERN	DESCRIPTION
	<p>The E.SYTANK AUXILIARY CITERN is supplied without any fittings or the E.SYDOCK. The tank has a modular design to couple easily with other E.SYTANK units, making the system expandable to the necessary capacity. It can be connected on three sides (at side and rear) using the E.SYTANK TANK COUPLING KIT.</p>

E.SYTANK COUPLING KIT	DESCRIPTION
	<p>The E.SYTANK COUPLING KIT is composed of a PVC sleeve with gasket (D.160 mm L=150), two PVC aligning pipes (D.50mm x L=60) and a connecting ring nut for a 2-pump option. It allows the connection of several E.SYTANK units or between E.SYTANK and E.SYTANKAUXILIARY CITERN.</p>

E.SYTANK OPTIONAL DELIVERY KIT	DESCRIPTION
	<p>Composed of a 1" PP pipe. It allows an auxiliary delivery for single tank systems or with the COUPLING KIT it allows several E.SYTANK and E.SYBOX systems to be linked together and to create pressure boosting units with several pumps and tanks.</p>

DIMENSIONS

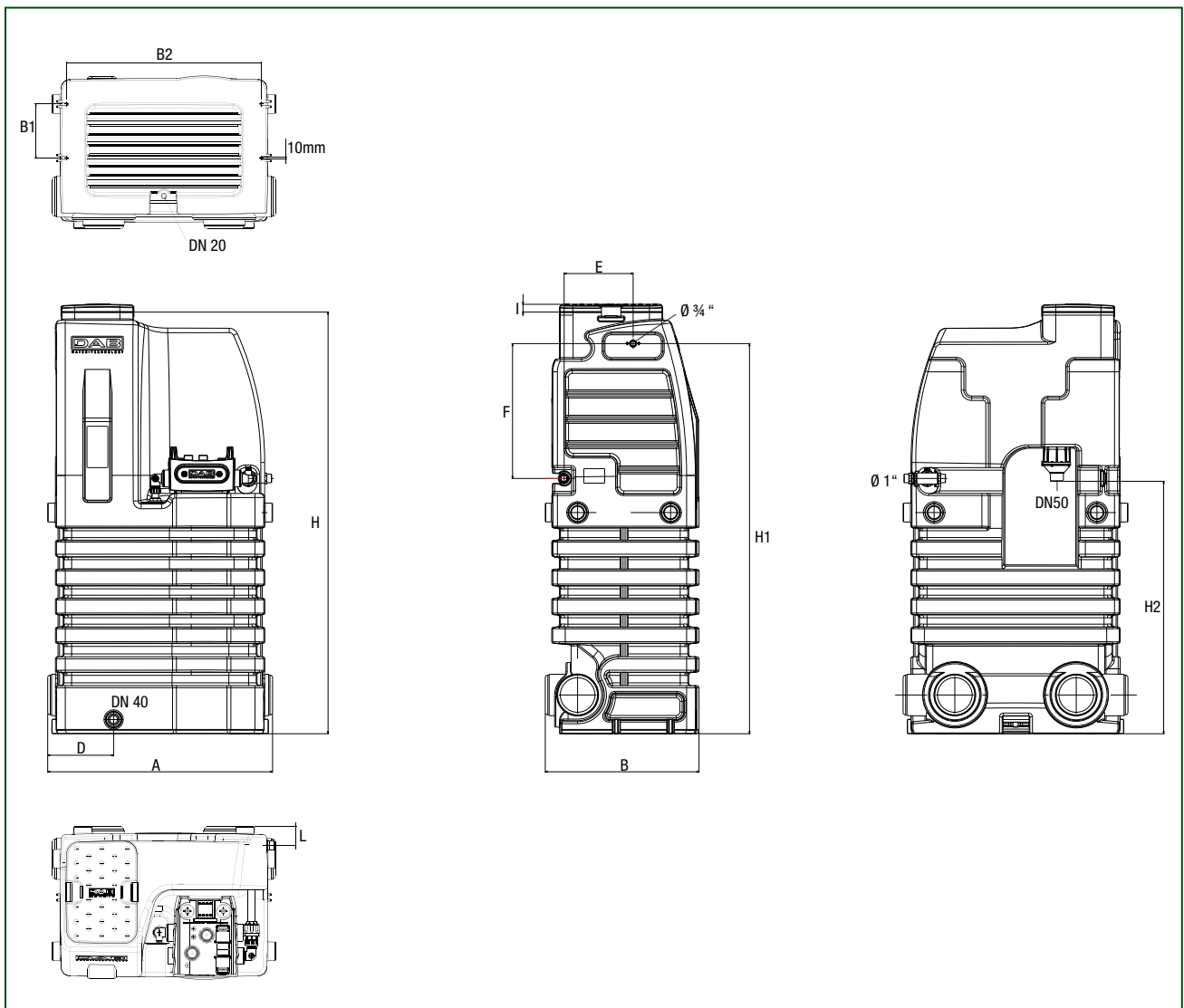

A	B	B1	B2	D	E	F	H	H1	H2	I	L	WEIGHT (Kg)
870	595	210	758	255	267	522	1632	1510	977	30	72	40

CONFIGURATION EXAMPLES

INDEX	DESCRIPTION
A	E.SYBOX
B	E.SYTANK
C	E.SYTANK AUXILIARY CITERN
D	E.SYTANK COUPLING KIT
E	E.SYTANK OPTIONAL DELIVERY KIT

1.INSTALLATION OF 2 E.SYBOX + 2 E.SYTANK

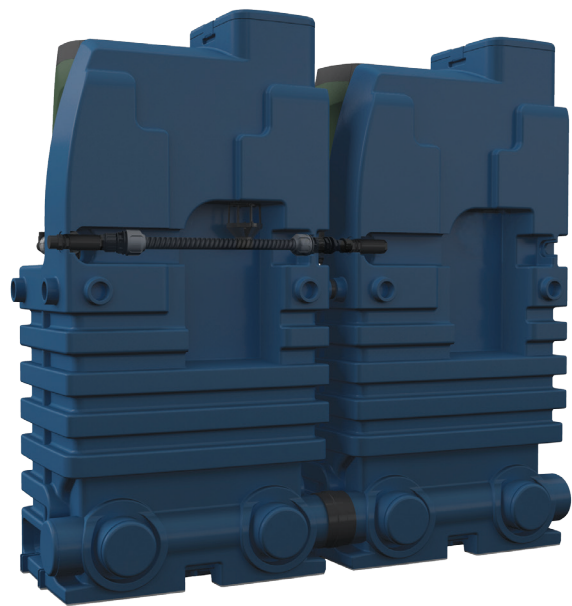

$2xA + 2xB + 1xD + 1xE^*$

*FOR CONFIGURATION 1 REQUIRED ITEMS ARE : 2 E.SYBOX + 2 E.SYTANK + 1 E.SYTANK COUPLING KIT + 1 E.SYTANK OPTIONAL DELIVERY KIT

E.SYTANK

DRINKING WATER STORAGE TANK

2.E.SYTANK EXPANSION WITH AUXILIARY TANK

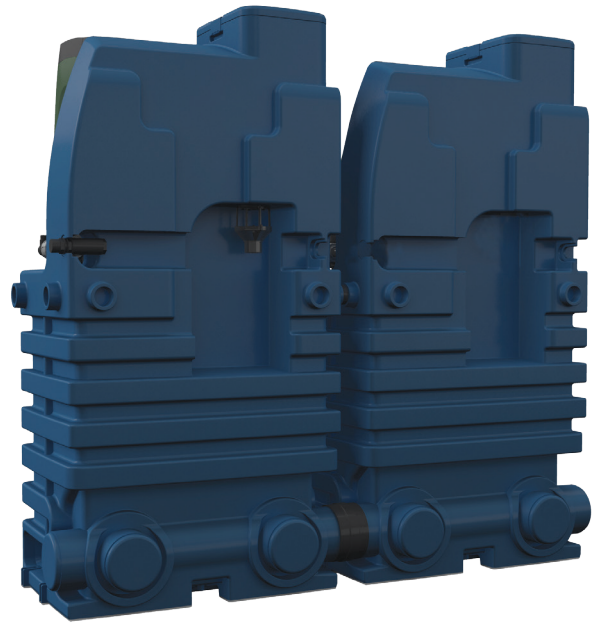

1xA + 1xB + 1xC + 1xD*

*FOR CONFIGURATION 2 REQUIRED ITEMS ARE: 1 E.SYBOX + 1 E.SYTANK + 1 E.SYTANK AUXILIARY CITERN + 1 E.SYTANK TANK COUPLING KIT

3.E.SYTANK INSTALLATION WITH DELIVERY OUTLET ON THE LEFT



1xA + 1xB + 1xE*

*FOR CONFIGURATION 3 REQUIRED ITEMS ARE: 1 E.SYBOX + 1 E.SYTANK + 1 X E.SYTANK OPTIONAL DELIVERY KIT



WATER • TECHNOLOGY

Via Marco Polo, 14 - Mestrino (PD) Italy - Phone +39.049.5125000 - Fax +39.049.5125950
www.dabpumps.com



DAB PUMPS LTD.
Unit 4 and 5, Stortford Hall Industrial Park,
Dunmow Road,
Bishops Stortford,
Herts
CM23 5GZ - UK
salesuk@dwtgroup.com
Tel. +44 1279 652 776
Fax +44 1279 657 727



DAB PUMPS B.V.
Albert Einsteinweg, 4
5151 DL Drunen - Nederland
info.netherlands@dwtgroup.com
Tel. +31 416 387280
Fax +31 416 387299



DWT South Africa
Podium at Menlyn,
3rd Floor, Unit 3001b, 43 Ingersol Road,
C/O Lois and Atterbury street,
Menlyn, Pretoria, 0181, South-Africa
info.sa@dwtgroup.com
Tel +27 12 361 3997
Fax +27 12 361 3137



DAB PUMPS B.V.
Brusselstraat 150
B-1702 Groot-Bijgaarden - Belgium
info.belgium@dwtgroup.com
Tel. +32 2 4668353
Fax +32 2 4669218



DAB PUMPEN DEUTSCHLAND GmbH
Tackweg 11
D - 47918 Tönisvorst - Germany
info.germany@dwtgroup.com
Tel. +49 2151 82136-0
Fax +49 2151 82136-36



DAB POLAND - Representative Office
Mokotow Marynarska
Ul. Postepu 15c - 3rd Floor
02-676 Warsaw - POLAND
Tel. +48 223 81 6085



PUMPS AMERICA, INC. DAB PUMPS DIVISION
3226 Benchmark Drive
Ladson, SC 29456 USA
info.usa@dwtgroup.com
Tel. 1-843-824-6332
Toll Free 1-866-896-4DAB (4322)
Fax 1-843-797-3366



DAB PUMPS IBERICA S.L.
Avenida de Castilla nr.1 Local 14
28830 - San Fernando De Henares - Madrid
Spain
info.spain@dwtgroup.com
Tel. +34 91 6569545
Fax: +34 91 6569676



DAB UKRAINE Representative Office
Regus Horizon Park
4 M. Hrinchenka St, suit 147
03680 Kiev, UKRAINE
Tel. +38 044 391 59 43



000 DWT GROUP
100 bldg. 3 Dmitrovskoe highway
127247 Moscow - Russia
info.russia@dwtgroup.com
Tel. +7 495 739 52 50
Fax +7 495 485-3618



DAB PUMPS CHINA
No.40 Kaituo Road, Qingdao Economic & Technological
Development Zone
Qingdao City, Shandong Province, China
PC: 266500
info.china@dwtgroup.com
Fax +8653286812210
Tel. +8653286812030-6270



DAB PRODUCTION HUNGARY KFT.
H-8800
NAGYKANIZSA, Buda Ernó u.5
HUNGARY
Tel. +36.93501700